

## NH Fuse-Links AC 400 V gG

Fuse-Links

In energy distribution, there is an ever increasing trend toward higher energy density. The number of distribution components such as circuit breakers, fuse switches, fuse bases increases while the size of cabinets keeps becoming even more compact. However, any cabinet can only handle a limited amount of power but also represents a major cost factor. The main application in energy distribution grids is the 230/400-V range.

Thanks to their significantly lower power dissipation, EFEN's 400-V fuse-links are optimally suited for the requirements of today and also save energy. The twin indicator ensures optimal visibility of the fuse status in all installations.

- Energy-saving design with 400-V fuse element
- Reduced power and heat dissipation
- Twin indicator ensures visibility in all installations

Power dissipation of 400 V and 500 V NH Fuse-Links compared

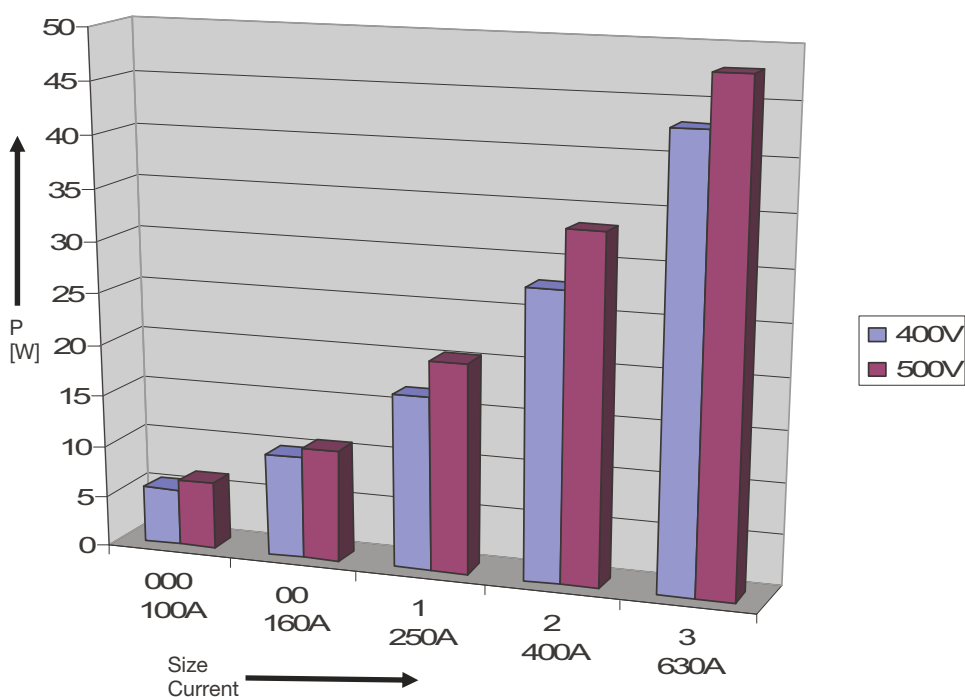

Annual power saving per fuse-link\*

Size	E
Current	[kWh]
NH 000 100A	2,6
NH 00 160A	2,9
NH 1 250A	9,2
NH 2 400A	14,5
NH 3 630A	13,1

\* 80% I<sub>n</sub> / ½ time

## NH Fuse-Links AC 400 V gG

Size	Amps	PU	Non-insulated metal gripping lugs Order no.	Insulated metal gripping lugs Order no.
000	2	3	35401-0020	35406-0020
000	4	3	35401-0040	35406-0040
000	6	3	35401-0060	35406-0060
000	10	3	35401-0100	35406-0100
000	16	3	35401-0160	35406-0160
000	20	3	35401-0200	35406-0200
000	25	3	35401-0250	35406-0250
000	32	3	35401-0320	35406-0320
000	35	3	35401-0350	35406-0350
000	40	3	35401-0400	35406-0400
000	50	3	35401-0500	35406-0500
000	63	3	35401-0630	35406-0630
000	80	3	35401-0800	35406-0800
000	100	3	35401-1000	35406-1000
00	125	3	35402-1250	35407-1250
00	160	3	35402-1600	35407-1600
1	16	3	35403-0160	35408-0160
1	20	3	35403-0200	35408-0200
1	25	3	35403-0250	35408-0250
1	32	3	35403-0320	35408-0320
1	35	3	35403-0350	35408-0350
1	40	3	35403-0400	35408-0400
1	50	3	35403-0500	35408-0500
1	63	3	35403-0630	35408-0630
1	80	3	35403-0800	35408-0800
1	100	3	35403-1000	35408-1000
1	125	3	35403-1250	35408-1250
1	160	3	35403-1600	35408-1600
1	200	3	35403-2000	35408-2000
1	224	3	35403-2240	35408-2240
1	250	3	35403-2500	35408-2500
2	35	3	35404-0350	35409-0350
2	50	3	35404-0500	35409-0500
2	63	3	35404-0630	35409-0630
2	80	3	35404-0800	35409-0800
2	100	3	35404-1000	35409-1000
2	125	3	35404-1250	35409-1250
2	160	3	35404-1600	35409-1600
2	200	3	35404-2000	35409-2000
2	224	3	35404-2240	35409-2240
2	250	3	35404-2500	35409-2500
2	315	3	35404-3150	35409-3150
2	355	3	35404-3550	35409-3550
2	400	3	35404-4000	35409-4000
3	250	1	35405-2500	35410-2500
3	300	1	35405-3000	35410-3000
3	315	1	35405-3150	35410-3150
3	400	1	35405-4000	35410-4000
3	425	1	35405-4250	35410-4250
3	500	1	35405-5000	35410-5000
3	630	1	35405-6300	35410-6300

For cable and line protection  
 Rated voltage: AC 400V  
 Utilization category: gG acc. to VDE 0636-2 and VDE 60269-2  
 Application: For cable and line protection  
 Breaking capacity: 100 kA

# NH Fuse-Links AC 400V gG

Fuse-Links

Time-current characteristics NH Fuse-Links of size 000 – 3, gG, 400 V AC, VDE 0636 part 2 and IEC 60269-2

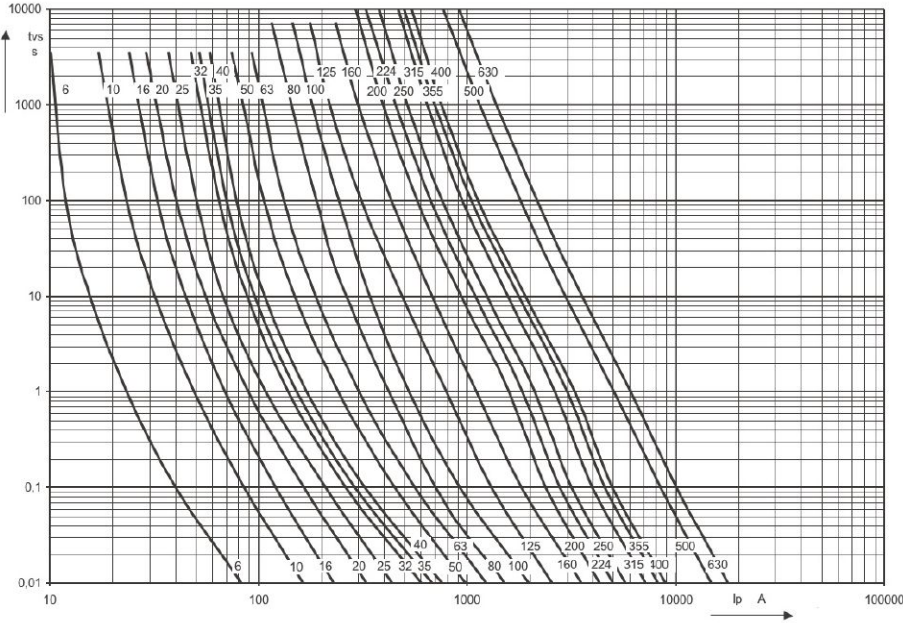

Cut-out current characteristics NH Fuse-Links size 000 – 3, gG, 400 V AC, VDE 0636 part 2 and IEC 60269-2

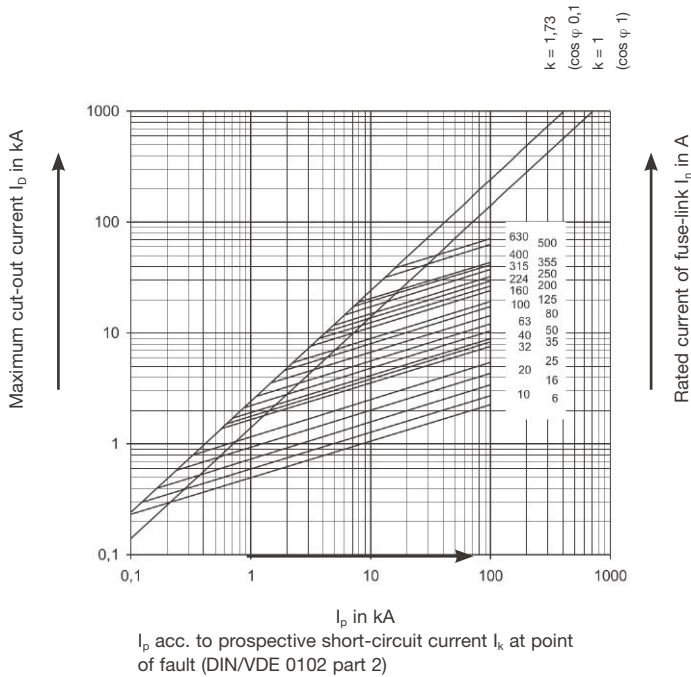

# NH Fuse-Links AC 400V gG

Rated power dissipation  $P_a$  in Watts of NH Fuse-Links size 000 – 3, gG, AC 400 V, acc. to VDE 0636 part 2 and IEC 60269-2

$I_n$ A	Size				
	000	00	1	2	3
6	1,7				
10	1,0				
16	1,8				
20	2,0				
25	2,4				
32	2,6				
35	3,2				
40	3,1				
50	3,5		4,5		
63	4,5	4,5	5,7		
80	5,0	5,0	5,5		
100	5,5	5,5	7,0	7,3	
125		8,6	9,1	9,1	
160		9,6	13,0	13,0	
200			13,1	13,5	
224			15,1	15,1	
250			16,9	18,0	
315				19,9	22,7
355				22,7	28,0
400				28,0	
500					30,8
630					43,0

Pre-arcing integrals and operating integrals in A<sup>2</sup>s NH Fuse-Links size 000 – 3, gG, AC 400 V, acc. to VDE 0636 part 2 and IEC 60269-2

$I_n$ A	Size									
	000		00		1		2		3	
	Pre-arcing	Operating	Pre-arcing	Operating	Pre-arcing	Operating	Pre-arcing	Operating	Pre-arcing	Operating
6	53	160								
10	115	570								
16	220	1 150								
20	455	2 400								
25	880	3 700								
32	2 450	9 000								
35	3 150	11 500			3 150	11 500	3 150	11 500		
40	3 950	14 000			3 950	14 000	-	-		
50	6 450	22 500			6 450	22 500	6 450	22 500		
63	9 950	35 500	9 950	35 500	9 950	35 500	9 950	35 500		
80	16 950	59 500	16 950	59 500	16 950	59 500	16 950	59 500		
100	28 500	100 300	28 500	100 300	28 500	100 300	28 500	100 300		
125			38 500	139 500	38 500	139 500	38 500	139 500		
160			76 500	279 000	76 500	279 000	76 500	279 000		
200					126 000	458 000	126 000	458 000		
224					171 000	610 000	171 000	610 000		
250					224 000	797 000	224 000	797 000	224 000	797 000
315							353 000	1 221 000	353 000	1 221 000
355							464 000	1 617 000	-	-
400							552 000	1 924 000	552 000	1 924 000
500									1 672 000	4 672 000
630									2 381 000	6 837 000

# NH Fuse-Links AC 500 V gG

Fuse-Links

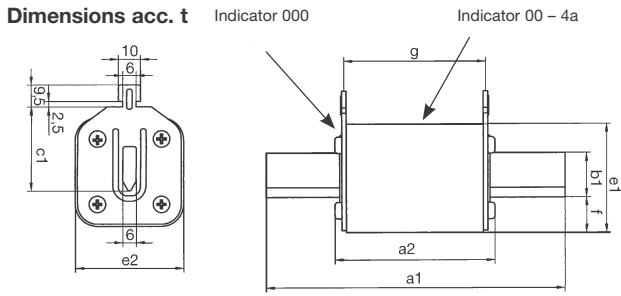

Size	Rated current	a <sub>1</sub>	a <sub>2</sub>	b <sub>1</sub>	c <sub>1</sub>	e <sub>1</sub>	e <sub>2</sub>	g
000		78,5	53	15	35	40	21	47
00	max. 160 A	78,5	53	15	35	47	30	47
1	max. 160 A	135	71	15	40	47	30	65
1	200 – 250 A	135	71	20	40	52	40	65
2	max. 250 A	150	72	20	48	52	40	65
2	300 – 400 A	150	72	26	48	60	51	65
3	max. 400 A	150	72	26	60	60	51	65
3	500 – 630 A	150	72	33	60	74	70	65
4a		200	96	50	85	109	98	86

**For cable and line protection**

Rated voltage: AC 500 V / DC see page 37  
 Utilization category: gG acc. to VDE 0636-2 and VDE 0636-1,  
 IEC 60269-1, IEC 60269-2

Application: For cable and line protection  
 Breaking capacity: 120 kA (AC 500 V) / DC see page 37

**Electrical characteristics:**

The time/current characteristics are matched to the cable and line capacities. Accordingly, the lines protected can be operated at optimal load as the breaking in case of overload is slow, but quick in the event of a short-circuit.

Even if devices of different brands are used that comply with the specifications, the definition of time-current ranges for category gG according to VDE 0636 and IEC 60269 ensures a selectivity of 1:1.6 at rated currents of ≥ 16 Amps.

Size	Amps	PU	Non-insulated metal gripping lugs Order no.	Insulated plastic gripping lugs Order no.	Insulated metal gripping lugs Order no.
000	2	3	35000-0020	35001-0020	
000	4	3	35000-0040	35001-0040	
000	6	3	35000-0060	35001-0060	
000	10	3	35000-0100	35001-0100	
000	16	3	35000-0160	35001-0160	
000	20	3	35000-0200	35001-0200	
000	25	3	35000-0250	35001-0250	
000	32	3	35000-0320	35001-0320	
000	35	3	35000-0350	35001-0350	
000	40	3	35000-0400	35001-0400	
000	50	3	35000-0500	35001-0500	
000	63	3	35000-0630	35001-0630	
000	80	3	35000-0800	35001-0800	
000	100	3	35000-1000	35001-1000	
00	2	3	35011-0010		35165-0010
00	4	3	35011-0020		35165-0020
00	6	3	35011-0030		35165-0030
00	10	3	35011-0040		35165-0040
00	16	3	35011-0050		35165-0050
00	20	3	35011-0060		35165-0060
00	25	3	35011-0070		35165-0070
00	32	3	35011-0080		35165-0080
00	35	3	35011-0090		35165-0090
00	40	3	35011-0100		35165-0100
00	50	3	35011-0110		35165-0110
00	63	3	35011-0120		35165-0120
00	80	3	35011-0130		35165-0130
00	100	3	35011-0140		35165-0140
00	125	3	35011-0150		35165-0150
00	160	3	35011-1090		35165-0160
1	25	3	35035-0050		35204-0050
1	32	3	35035-1220		35204-0160
1	35	3	35035-0060		35204-0060
1	40	3	35035-1230		35204-0170
1	50	3	35035-0070		35204-0070
1	63	3	35035-0080		35204-0080
1	80	3	35035-0090		35204-0090
1	100	3	35035-0100		35204-0110
1	125	3	35035-0110		35204-0110
1	160	3	35035-0120		35204-0120
1	200	3	35035-0130		35204-0130
1	224	3	35035-0140		35204-0140
1	250	3	35035-0150		35204-0150

# NH Fuse-Links AC 500 V gG

Size	Amps	PU	Non-insulated metal gripping lugs Order no.	Insulated metal gripping lugs Order no.
2	25	3	35054-0010	
2	35	3	35054-0020	
2	50	3	35054-0030	
2	63	3	35054-0040	35116-0040
2	80	3	35054-0050	35116-0050
2	100	3	35054-0060	35116-0060
2	125	3	35054-0070	35116-0070
2	160	3	35054-0080	35116-0080
2	200	3	35054-0090	35116-0090
2	224	3	35054-0100	35116-0100
2	250	3	35054-0110	35116-0110
2	(300)	3	35054-0120	35116-0120
2	315	3	35054-0130	35116-0130
2	(355)	3	35054-0140	35116-0140
2	400	3	35054-0150	35116-0150
3	63	3	35078-0340	35420-1000
3	80	3	35078-0350	35420-1250
3	100	3	35078-0360	35420-1600
3	125	3	35078-0370	35420-2000
3	160	3	35078-0380	35420-2240
3	200	3	35078-0390	35420-2500
3	224	3	35078-0400	35420-3000
3	250	3	35078-0410	35420-3150
3	(300)	3	35078-0190	35420-3550
3	315	3	35078-0010	35420-4000
3	(355)	3	35078-0020	35420-4250
3	400	3	35078-0030	35420-5000
3	(425)	3	35078-0040	35420-6300
3	500	3	35078-0050	
3	630	3	35078-0060	
4a	400	1	35097-0120	
4a	500	1	35097-0010	
4a	630	1	35097-0020	
4a	800	1	35097-0030	
4a	1000	1	35097-0040	
4a	1250	1	35097-0050	
4a	1600	1	35097-0110	

### Breaking capacity DC 500 V gG fuses:

Size 000:	40 kA, 250 V DC
Size 00:	40 kA, 250V DC
Size 1:	40 kA, 250 V DC
	80 kA, 400 V DC
Size 2:	40 kA, 250 V DC
	80 kA, 440 V DC
Size 3:	40 kA, 250 V DC
	80 kA, 400 V DC
Size 4a:	80 kA, 440 V DC

( ) = Dimensions according to DIN, rated current not standardized in VDE 0636

### NH Fuse-Links size 00 with striker

In combination with a micro switch, EFEN NH fuse-links size 00 with striker can be used for fuse monitoring.

### Force-distance diagram of the striker

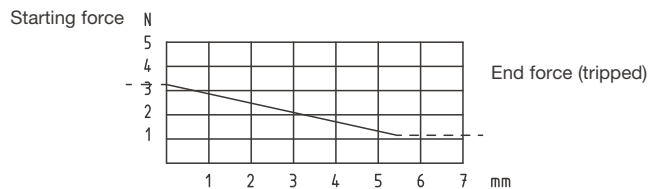

### NH Fuse-Links for cable and line protection size 00, 500 V AC, utilization category gL/gG, with striker

Amps	Designation	Order no.
6	NH-Si 00 6A gL SM	35207-0010
10	NH-Si 00 10A gL SM	35207-0020
16	NH-Si 00 16A gL SM	35207-0030
20	NH-Si 00 20A gL SM	35207-0040
25	NH-Si 00 25A gL SM	35207-0050
32	NH-Si 00 32A gL SM	35207-0060
35	NH-Si 00 35A gL SM	35207-0070
40	NH-Si 00 40A gL SM	35207-0080
50	NH-Si 00 50A gL SM	35207-0090
63	NH-Si 00 63A gL SM	35207-0100
80	NH-Si 00 80A gL SM	35207-0110
100	NH-Si 00 100A gL SM	35207-0120
125	NH-Si 00 125A gL SM	35207-0130

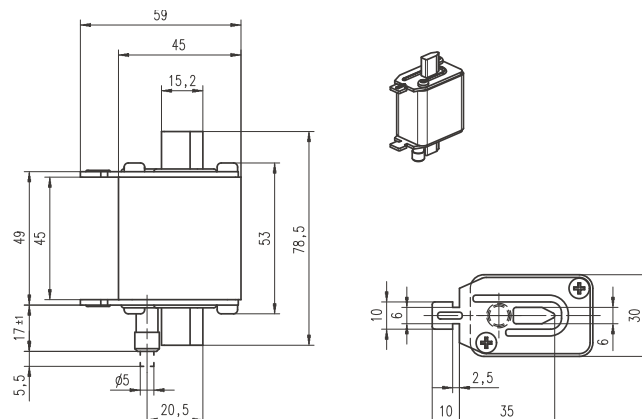

# NH Fuse-Links AC 500 V gG

Fuse-Links

For cable and line protection  
 Time-current characteristics NH Fuse-Links size 000 acc. to VDE 0636-2 and IEC/EN 60269-2

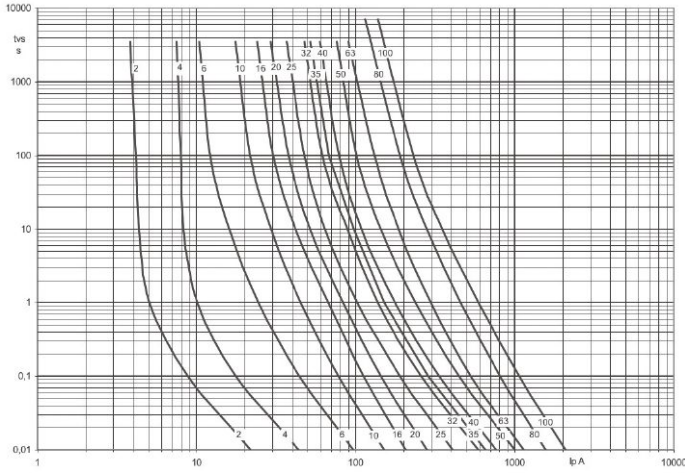

Time-current characteristics NH Fuse-Links size 00 – 4a gG 500 V AC acc. to VDE 0636-2 and IEC/EN 60269-2

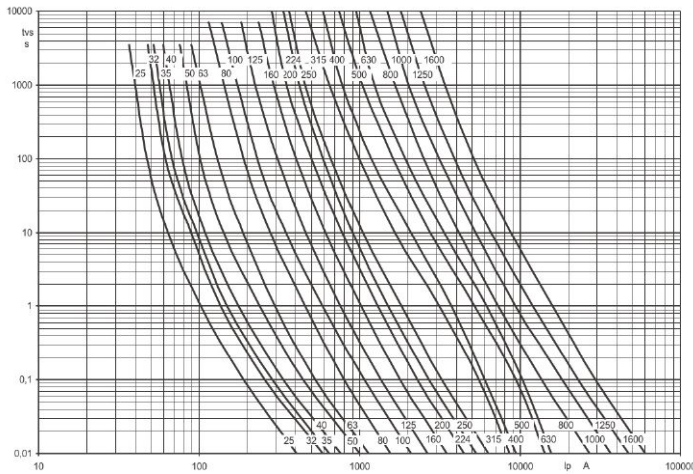

Cut-out current characteristics acc. to VDE 0636-2 and IEC/EN 60269-2

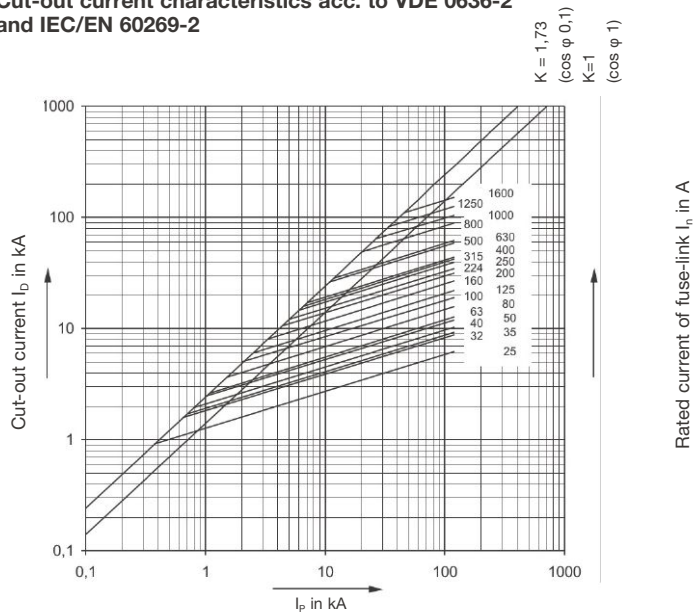

$I_p$  acc. to prospective short-circuit current  $I_k$  at point of fault (DIN/VDE 0102 part 2)

# NH Fuse-Links AC 500 V gG

Rated power dissipation  $P_w$  warm NH Fuse-Links size 000 – 4a gG AC 500 V acc. to VDE 0636-2 and IEC/EN 60269-2

$I_n$ A	Size					
	000	00	1	2	3	4a
6	1,6					
10	1,1					
16	1,8		1,8			
20	2,3		2,3			
25	2,4	2,4	2,4			
32	3,1	3,1	3,1			
35	3,0	3,0	3,0			
40	3,7	3,7	3,7			
50	4,1	4,1	4,1	4,1		
63	5,4	5,6	6,6	6,8		
80	6,5	6,8	8,0	8,3		
100	7,5	7,5	9,4	10,7		
125		10,0	11,8	12,2		
160		12,0	14,6	15,0		
200			18,0	18,5		
224			19,0	19,2	20,0	
250			20,0	20,6	21,1	
315				25,0	25,0	
355				31,5	32,0	
400				28,5	34,0	31,2
500					43,0	36,5
630					43,1	44,4
800						68,0
1000						72,9
1250						100,5
1600						126,2

Pre-arcing integrals and operating integrals in A<sup>2</sup>s of NH Fuse-Links size 000 – 4a, gG, AC 500 V, acc. to VDE 0636-2 and IEC/EN 60269-2

$I_n$ A	Size											
	000		00		1		2		3		4a	
	Pre-arcing	Operating	Pre-arcing	Operating	Pre-arcing	Operating	Pre-arcing	Operating	Pre-arcing	Operating	Pre-arcing	Operating
6	53,6	280										
10	109	490										
16	199	890										
20	430	1930										
25	890	4010	890	4010	990	4010	990	4010				
32	2475	6900	2475	6900	2475	6900	2475	6900				
35	2990	8380	2990	8380	2990	8380	2990	8380				
40	3970	10100	3970	10100	3970	10100	3970	10100				
50	6330	16150	6330	16150	6330	16150	6330	16150				
63	7430	20800	7430	20800	7430	20800	7430	20800	7430	20800		
80	14250	39900	14250	39900	14250	39900	14250	39900	14250	39900		
100	25340	70900	25340	70900	25340	71000	25340	71000	25340	71000		
125			39600	110800	39600	111000	39600	111000	39600	111000		
160			70400	197100	70400	197100	70400	197100	70400	197100		
200					114400	320000	114400	320000	114400	320000		
224					158400	444000	158400	444000	158400	444000		
250					228000	639000	228000	639000	228000	639000		
315							275900	773000	275900	773000		
355							356400	998000	356400	998000		
400							431200	1207000	431200	1207000	610500	927000
500									766600	2147000	1025 10 <sup>3</sup>	1618 10 <sup>3</sup>
630									912300	3013000	1767 10 <sup>3</sup>	2600 10 <sup>3</sup>
800											3499 10 <sup>3</sup>	5449 10 <sup>3</sup>
1000											5878 10 <sup>3</sup>	8708 10 <sup>3</sup>
1250											12164 10 <sup>3</sup>	18676 10 <sup>3</sup>
1600											20347 10 <sup>3</sup>	31278 10 <sup>3</sup>

# NH Fuse-Links 500 V AC gL

Fuse-Links

### For cable and line protection in meshed main systems

(ageing-resistant)  
 Rated voltage: AC 500 V  
 Utilization category: gL/gG acc. to VDE 0636-21 and IEC 60269-2  
 Application: For cable and line protection  
 Breaking capacity: 120 kA (size 00 – 2)

### Electrical characteristics

The time/current characteristics are matched to the cable and line capacities. Accordingly, the lines protected can be operated at optimal load as the breaking in case of overload is slow, but quick in the event of a short-circuit.

Even if devices of different brands are used that comply with the specifications, the definition of time-current ranges for category gL/gG acc. to VDE 0636 and IEC 60269-2 ensures a selectivity of 1:1.6. EFEN 500 V gL/gG fuse-links used in a 400 V grid have a selectivity of 1:1.25 for rated currents  $\geq 16$  A, i.e. between the increments of the rated currents.

EFEN PURE SILVER NH fuse-links 500 V gL/gG are specifically suited for use in meshed mains systems and show a selectivity factor of 0.79 when used in 400 V grids. Accordingly, if the maximum partial short-circuit current does not exceed 79% of the total short-circuit current, only the fuse-link closest to the failure point will be tripped. Thanks to the pure silver fuse element, this favourable factor is maintained throughout the component's entire service life.

Note: When used in meshed main systems, standard indicators do usually not respond reliably because of the low differential voltages. Please inquiry for a solution by EFEN.

### Dimensions: DIN 43620-1

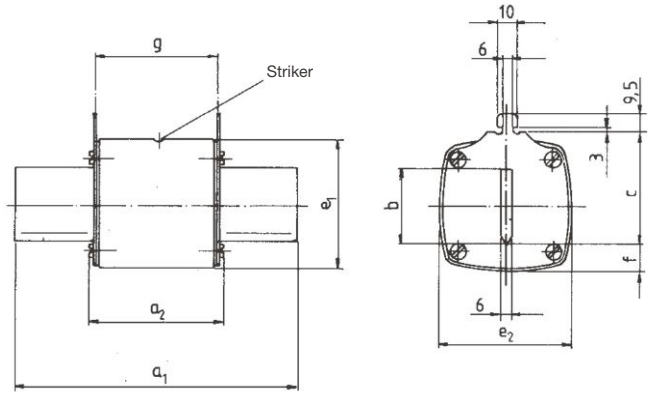

Size	a <sub>1</sub>	a <sub>2</sub>	b	c	e <sub>1</sub>	e <sub>2</sub>	f	g
00 <sup>1)</sup>	78,5	53	15	35	40	28	12,5	47
0	125	67	15	35	38	35	11,5	65
1 <sup>2)</sup>	135	74	20	40	38	35	9	65
1 <sup>3)</sup>	135	74	24,5	40	45	45	10	65
2 <sup>4)</sup>	150	74	25	48	45	45	10	65
2 <sup>5)</sup>	150	72	30	48	59	59	14,5	65
3 <sup>6)</sup>	150	72	40	60	70	70	15	65

- <sup>1)</sup> Rated current up to 160 A
- <sup>2)</sup> Rated current up to 125 A
- <sup>3)</sup> Rated current 160 – 250 A
- <sup>4)</sup> Rated current up to 250 A
- <sup>5)</sup> Rated current 300 – 400 A
- <sup>6)</sup> Rated current up to 630 A

### Rated power dissipation in Watts NH Fuse-Links Size 00 – 3 gL AC 500 V VDE 0636-2 and IEC/EN 60269-2

I <sub>n</sub> A	Size			
	00	1	2	3
2	0,25			
4	0,5			
6	1,0			
10	1,5			
16	1,9			
20	2,0			
25	2,2			
35	3,0			
50	3,75			
63	4,5			
80	4,8			
100	5,8			
125	8,8			
160	9,7			
200		15,7		
224		15,8		
250		16,4		
315			24,3	
355			26,2	
400			28,1	
500				33,0
630				42,0

### Breaking capacity DC 500 V gL

Size 00: 35 kA, 250V DC  
 Size 1: 35 kA, 440 V DC  
 Size 2: 35 kA, 440 V DC

# NH Fuse-Links 500 V AC gL

Time-current characteristics acc. to VDE 0636-2 and IEC/EN 60269-2

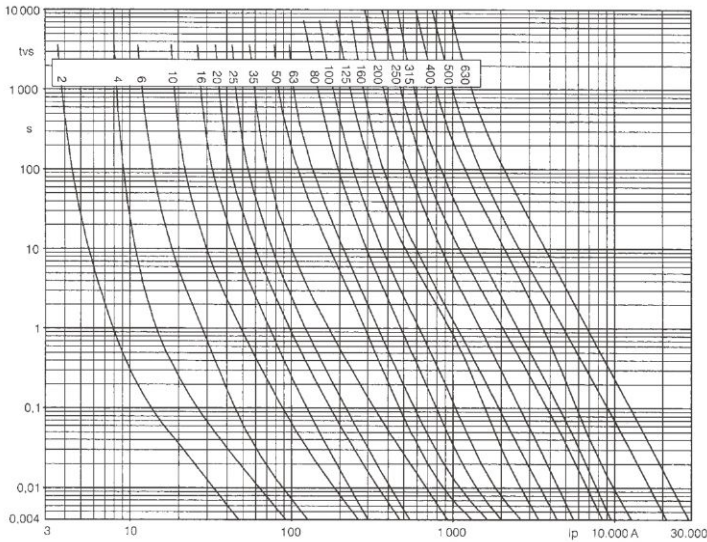

Cut-out current characteristics acc. to VDE 0636-2 and IEC/EN 60269-2

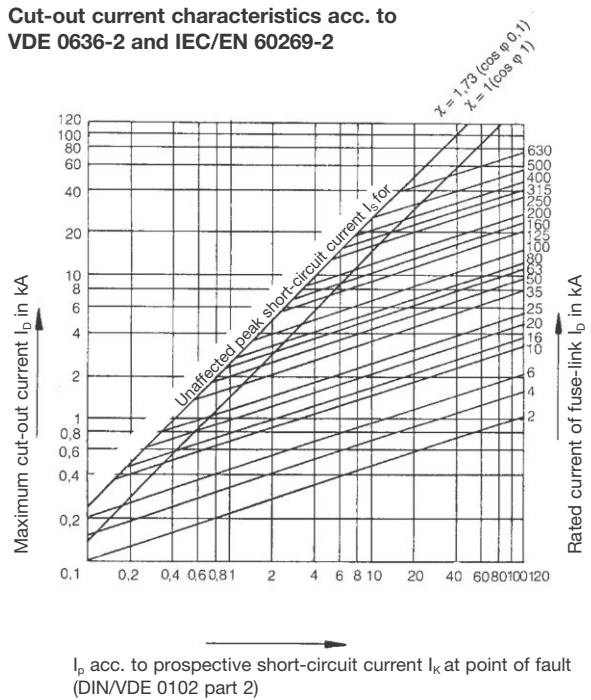

$I_p$  acc. to prospective short-circuit current  $I_k$  at point of fault (DIN/VDE 0102 part 2)

Rated power dissipation acc. to VDE 0636-2 and IEC/EN 60269-2

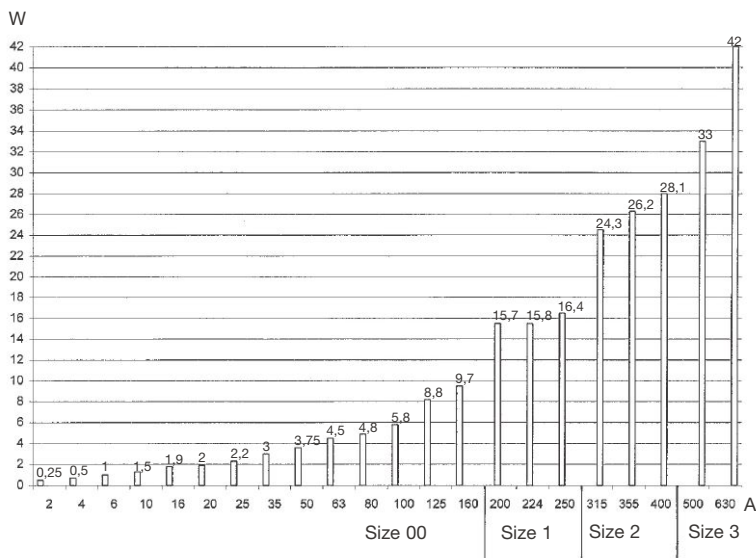

Pre-arcing and operating integrals acc. to VDE 0636-2 and IEC/EN 60269-2

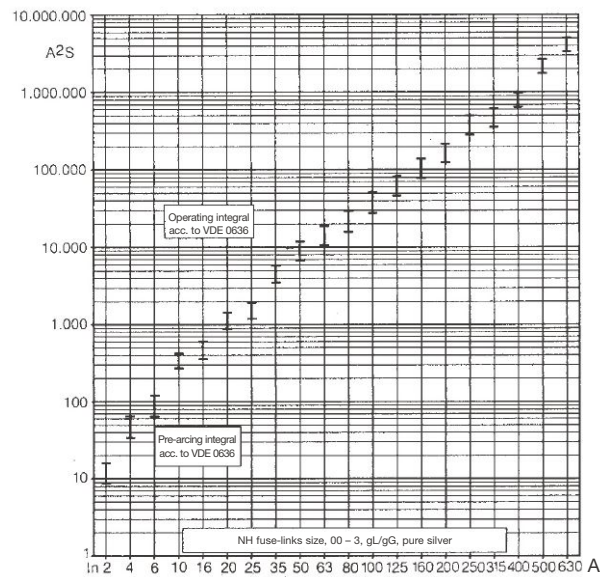

# NH Fuse-Links AC 690 V gG

Fuse-Links

**For cable and line protection**

Rated voltage: AC 690 V  
 Utilization category: gG acc. to VDE 0636-2 and VDE 0636-1, IEC 60269-2, IEC 60269-1  
 Application: For cable and line protection  
 Breaking capacity: 100 kA (630 A, 50 kA)

**Electrical characteristics:**

The time/current characteristics are matched to the cable and line capacities. Accordingly, the lines protected can be operated at optimal load as the breaking in case of overload is slow, but quick in the event of a short-circuit.

Size	Amps	PU	Metal gripping lugs Order no.
000	2	3	35421-0020
000	4	3	35421-0040
000	6	3	35421-0060
000	10	3	35421-0100
000	16	3	35421-0160
000	20	3	35421-0200
000	25	3	35421-0250
000	32	3	35421-0320
000	35	3	35421-0350
000	40	3	35421-0400
000	50	3	35421-0500
000	63	3	35421-0630
000	80	3	35422-0800
000	100	3	35422-1000
000	125	3	35422-1250
1	25	3	35423-0250
1	32	3	35423-0320
1	35	3	35423-0350
1	40	3	35423-0400
1	50	3	35423-0500
1	63	3	35423-0630
1	80	3	35423-0800
1	100	3	35423-1000
1	125	3	35423-1250
1	160	3	35423-1600
1	200	3	35423-2000
1	250	3	35423-2500
2	25	3	35424-0250
2	35	3	35424-0350
2	50	3	35424-0500
2	63	3	35424-0630
2	80	3	35424-0800
2	100	3	35424-1000
2	125	3	35424-1250
2	160	3	35424-1600
2	200	3	35424-2000
2	250	3	35424-2500
2	315	3	35424-3150
2	355	3	35424-3550
2	400	3	35424-4000
3	80	3	35425-0800
3	100	3	35425-1000
3	125	3	35425-1250
3	160	3	35425-1600
3	200	3	35425-2000
3	224	3	35425-2240
3	250	3	35425-2500
3	315	3	35425-3150
3	355	3	35425-3550
3	400	3	35425-4000
3	425	3	35425-4250
3	500	3	35425-5000
3	630	3	35425-6300

**Dimensions: DIN 43620-1**

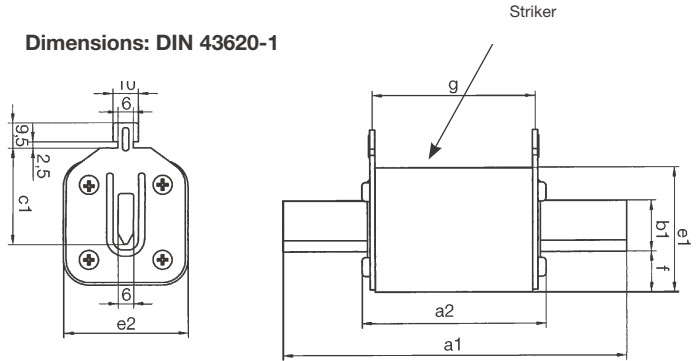

Size	Rated current	a <sub>1</sub>	a <sub>2</sub>	b <sub>1</sub>	c <sub>1</sub>	e <sub>1</sub>	e <sub>2</sub>	g
000	6-63 A	78,5	53	15	35	37	21	47
00	80-100 A	78,5	53	15	35	45	30	47
1	25-160 A	135	70	15	40	45	30	65
1	200-250 A	135	70	20	40	50	50	65
2	25-250 A	150	71	20	48	50	50	65
2	315-400 A	150	71	26	48	58	58	65
3	63-400 A	150	71	26	60	58	58	65
3	500 A, 630 A	150	74	32	60	71	71	65

**Rated power dissipation P<sub>a</sub> in Watts NH Fuse-Links size 000 – 3 gG AC 690 V VDE 0636-2 IEC 60269-2**

I <sub>n</sub> A	Size				
	000	00	1	2	3
2	1,9				
4	1,5				
6	1,6				
10	1,7				
16	2,5				
20	2,6				
25	2,8		3,6		
32	3,1		3,7		
35	3,2		3,9	3,7	
40	3,7		4,4	4,4	
50	4,1		4,8	5,4	
63	5,4		6,6	6,8	
80		6,8	8,0	8,3	
100		7,5	9,4	10,7	
125		10,0	11,8	12,2	
160			14,6	15,5	
200			19,0	19,0	
224			-	-	
250			22,0	22,0	21,1
315				27,0	25,0
355				32,0	32,0
400					34,0
500					43,0
630					52,0

( ) = Dimensions according to DIN, rated current not standardized in VDE 0636

# NH Fuse-Links AC 690 V gG

For cable and line protection

Time-current characteristics acc. to VDE 0636-2 and IEC/EN 60269-2

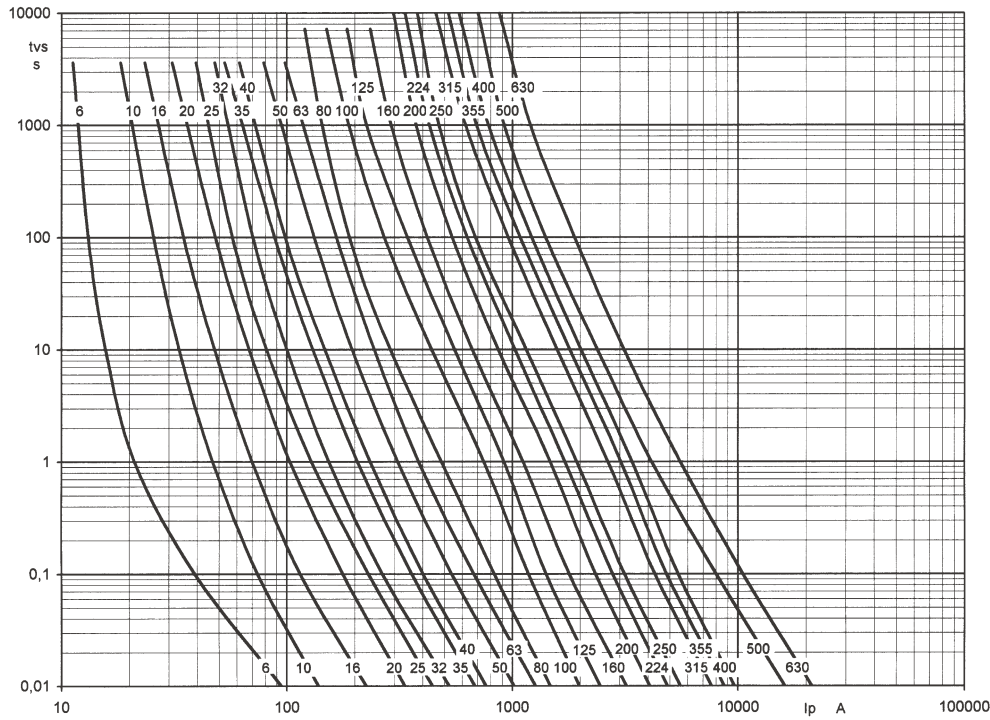

Cut-out current characteristics acc. to VDE 0636-2 and IEC/EN 60269-2

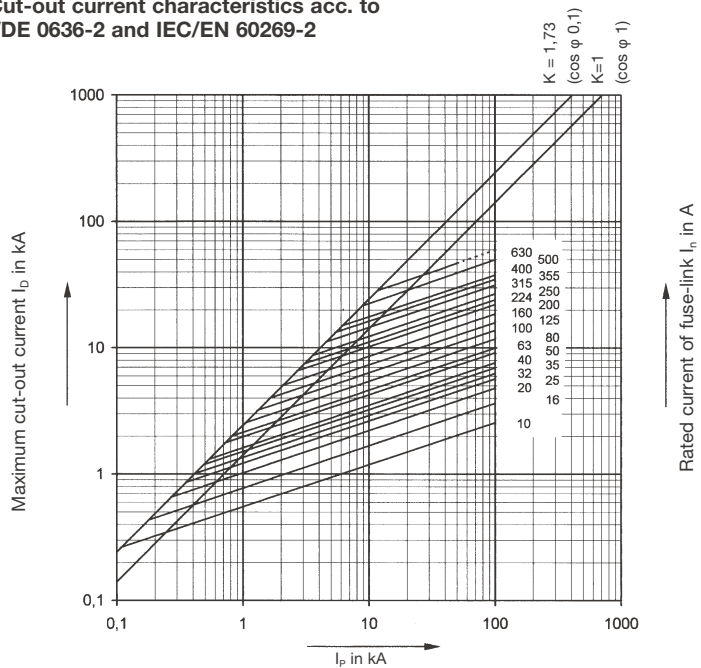

$I_p$  acc. to prospective short-circuit current  $I_k$  at point of fault (DIN/VDE 0102 part 2)

Breaking capacity of DC 690 V gG fuses:

- Size 000: 40 kA, 250 V DC
- Size 00: 40 kA, 250 V DC
- Size 1: 80 kA, 440 V DC
- Size 2: 40 kA, 250 V DC
- 80 kA, 440 V DC
- Size 3: 40 kA, 250 V DC
- 80 kA, 400 V DC

# NH Fuse-Links AC 400 V gTr

Fuse-Links

**For transformer protection**

Rated voltage: AC 400 V  
 Utilization category: gTr acc. to VDE 0636-2011  
 Application: For transformer protection  
 Breaking capacity: 100 kA

Size	Amps	kVA	PU	Metal gripping lugs Order no.
2	(72)	50	3	35076-1010
2	(108)	75	3	35076-1020
2	(144)	100	3	35076-1030
2	(180)	125	3	35076-1040
2	(231)	160	3	35076-1050
2	(289)	200	3	35076-1060
2	(361)	250	3	35076-1070
3	(144)	100	3	35081-1040
3	(231)	160	3	35081-1060
3	(289)	200	3	35081-1050
3	(361)	250	3	35081-1010
3	(455)	315	3	35081-1020
3	(577)	400	3	35081-1030
3	(722)	500	3	35081-0100
3	(909)	630	3	35081-0110
4a	(144)	100	1	35100-0100
4a	(231)	160	1	35100-0110
4a	(289)	200	1	35100-0160
4a	(361)	250	1	35100-0120
4a	(455)	315	1	35100-0170
4a	(577)	400	1	35100-0130
4a	(722)	500	1	35100-0140
4a	(909)	630	1	35100-0150
4a	(1155)	800	1	35100-0040
4a	(1443)	1000	1	35100-0190

( ) = Dimensions according to DIN, rated current not standardized in VDE 0636

**Electrical characteristics:**

Time-current characteristics are matched to the thermal capacity of the transformers and the time-current characteristics of the high-voltage fuse-links. The gTr fuse-link supplements the high-voltage fuse-link in the "non-permissible" overcurrent range. This allows a better utilization of the transformers' overload capacities. EFEN transformer fuse-links are able to carry the 1.3-fold of the transformer rated current for a minimum period of 10 hours. The fuse-link trips at the 1.5-fold transformer rated current within a period of 2 hours. Transformer fuse-links are designated in accordance with the transformer rated current in kVA.

**Dimensions: DIN 43620-1**

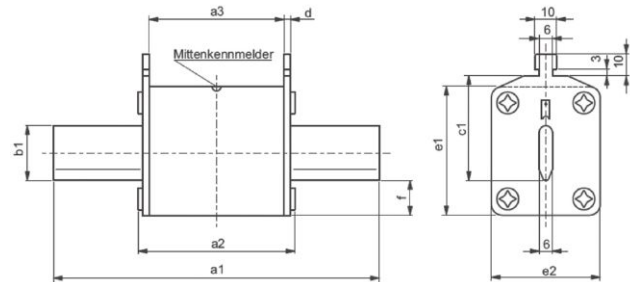

**NH Fuse-Links AC 400 V gTr with non-insulated gripping lugs**

Size	Rated current	a1	a2	a3	d	b1	c1	e1	e2	f
2/	50 – 160 kVA	150	72	62	2,5	20	48	48	40	12
2	200 – 250 kVA	150	72	62	2,5	25	48	59	50	14
3/	100 – 250 kVA	150	73	62	2,8	25	60	59	50	13
3	315 – 630 kVA	150	73	62	2,8	32	60	71	71	17
4a/	100 – 400 kVA	200	96	84	3	32	85	71	73	18
4	500 – 1000 kVA	200	96	84	4	50	85	109	98	27

**Rated power dissipation P<sub>a</sub> in Watts of NH Fuse-Links size 2 – 4a gTr AC 400 V VDE 0636 part 2011**

Transformer rated output	Rated current	Size		
		2	3	4a
50	72	5,5	5,5	
75	102	7,8	7,8	
100	144	10,6	10,1	12,0
125	180	12,8	12,8	15,0
160	231	15,7	16,2	14,8
200	289	16,0	16,0	22,5
250	361	21,0	20,6	28,0
315	455	25,0	25,0	31,5
400	577		31,0	39,0
500	722		53,0	49,0
630	909		62,0	66,0
800	1155			81,0
1000	1443			110,0

# NH Fuse-Links AC 400 V gTr

For transformer protection

Time-current characteristics acc. to VDE 0636-2 and IEC/EN 60269-2

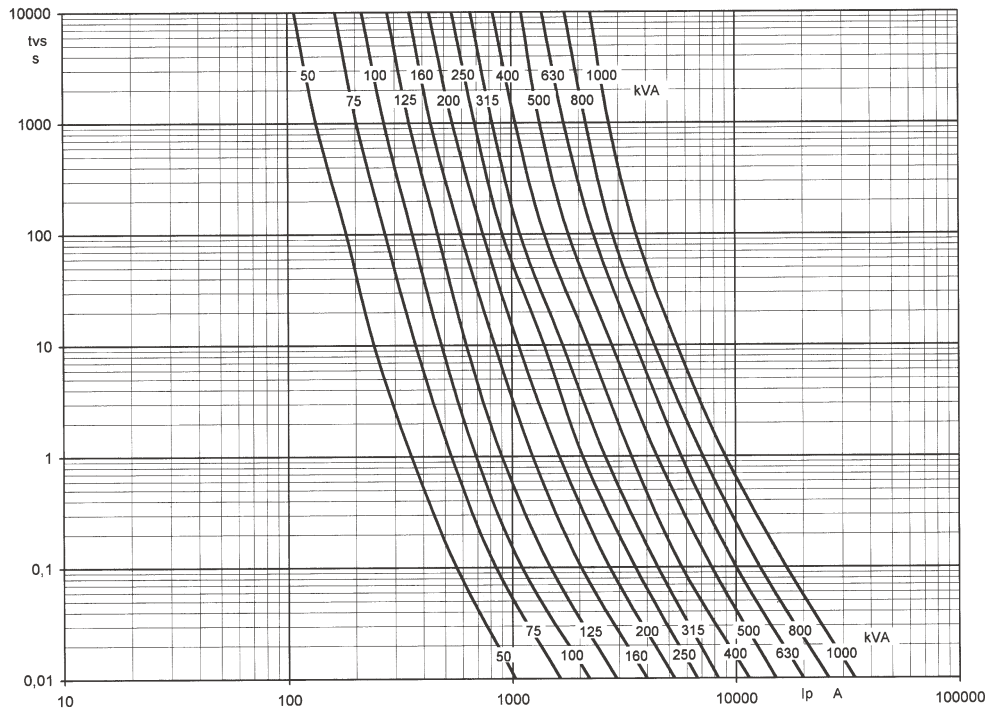

Cut-out current characteristics acc. to VDE 0636-2 and IEC/EN 60269-2

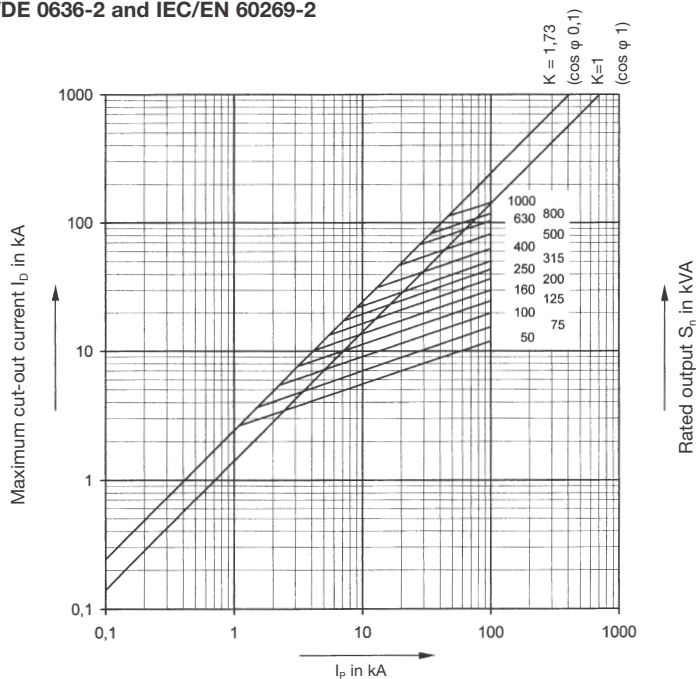

$I_p$  acc. to prospective short-circuit current  $I_k$  at point of fault (DIN/VDE 0102 part 2)

# NH Fuse-Links AC 500 V gR

Fuse-Links

**For semiconductor protection – pure silver fuse element**  
 Rated voltage: AC 500 V  
 Utilization category: gR acc. to VDE 0636-4  
 Application: For semiconductor protection  
 Breaking capacity: 120 kA

**Without striker**

Size	Amps	PU	Metal gripping lugs Order no.
00	16	3	35024-0180
00	20	3	35024-0170
00	25	3	35024-0190
00	35	3	35024-0010
00	40	3	35024-0020
00	50	3	35024-0030
00	63	3	35024-0040
00	80	3	35024-0050
00	100	3	35024-0060
00	125	3	35024-0070
00	160	3	35024-0080
1	35	3	35040-0010
1	50	3	35040-0020
1	63	3	35040-0030
1	80	3	35040-0040
1	100	3	35040-0050
1	125	3	35040-0060
1	160	3	35040-0070
1	200	3	35040-0080
1	(224)	3	35040-0090
1	250	3	35040-0100
2	80	3	35058-0010
2	100	3	35058-0020
2	125	3	35058-0030
2	160	3	35058-0040
2	200	3	35058-0050
2	(224)	3	35058-0060
2	250	3	35058-0070
2	(300)	3	35058-0080
2	315	3	35058-0090
2	(355)	3	35058-0100
2	400	3	35058-0110
3	315	1	35079-0010
3	(355)	1	35079-0020
3	400	1	35079-0030
3	(425)	1	35079-0040
3	500	1	35079-0050
3	630	1	35079-0060

( ) = Dimensions according to DIN,  
 rated current not standardized in VDE 0636

**Dimensions: DIN 43620-1**

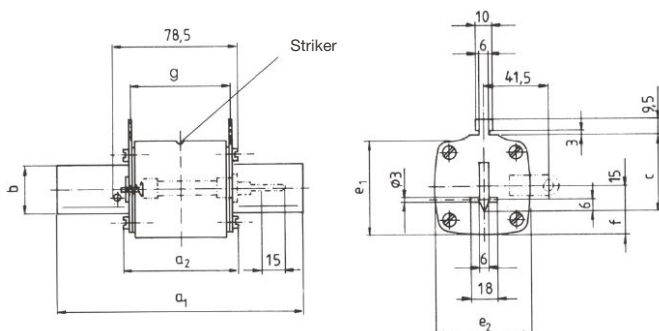

**Electrical characteristics:**

EFEN NH fuse-links for semiconductor protection feature the following properties:

1. ultra-quick time-current characteristics adjusted to protection requirements
  2. a low arc voltage characteristic with low overvoltage
- EFEN gR fuse-links may be used as full-range fuses for overload and short-circuit protection or in conjunction with other overcurrent protection devices to provide short-circuit protection only.

**Variant with striker:**

A spring-loaded striker pin is provided in parallel with the fuse-link. When the NH fuse-link trips, the striker pin is released, actuating the micro-switch on the NH fuse-base.

**With striker**

Size	Amps	PU	Metal gripping lugs Order no.
00	16	3	35218-0010
00	20	3	35218-0020
00	25	3	35218-0030
00	35	3	35218-0040
00	40	3	35218-0050
00	50	3	35218-0060
00	63	3	35218-0070
00	80	3	35218-0080
00	100	3	35218-0090
00	125	3	35218-0100
1	35	1	35046-0010
1	50	1	35046-0020
1	63	1	35046-0030
1	80	1	35046-0040
1	100	1	35046-0050
1	125	1	35046-0060
1	160	1	35046-0070
1	200	1	35046-0080
1	(224)	1	35046-0090
1	250	1	35046-0100
2	80	1	35060-0050
2	100	1	35060-0060
2	125	1	35060-0070
2	160	1	35060-0080
2	200	1	35060-0090
2	(224)	1	35060-0100
2	250	1	35060-0110
2	(300)	1	35060-0120
2	(315)	1	35060-0130
2	355	1	35060-0140
2	400	1	35060-0150
3	315	1	35086-0010
3	(355)	1	35086-0020
3	400	1	35086-0030
3	(425)	1	35086-0040
3	500	1	35086-0050
3	630	1	35086-0060

Size	a <sub>1</sub>	a <sub>2</sub>	b	c	e <sub>1</sub>	e <sub>2</sub>	f	g
00	78,5	53	15	35	40	28	12,5	47
0	125	67	15	35	38	35	11,5	65
1	135	71	24,5	40	45	45	10	65
2	150	72	30	48	59	59	14,5	65
3	150	72	40	60	70	70	15	65

## NH Fuse-Links AC 500 V gR

Rated power dissipation in Watts of NH Fuse-Links size 00 – 3  
gR AC 500 V VDE 0636-4

I <sub>n</sub> A	Size			
	00	01	2	3
16	6,0			
20	7,2			
25	8,0			
35	9,6	12,6		
50	12,0	14,0		
63	14,0	17,2		
80	17,7	21,2	20,0	
100	25,7	27,5	27,1	
125	29,7	31,2	29,7	
160	45,3	38,0	35,5	
200		46,0	43,9	
224		56,9	51,9	
250		65,0	56,8	
300			<b>67,7</b>	
315			68,7	67,7
355			80,6	77,5
400			91,6	88,5
425				97,2
500				115,7
630				168,3

Breaking capacity DC 500 V gR

Size 00: 25 kA, 240 V DC  
 Size 1: 25 kA, 440 V DC  
 Size 2: 25 kA, 440 V DC  
 Size 3: 25 kA, 440 V DC

# NH Fuse-Links AC 500 V gR

Fuse-Links

For semiconductor protection – pure silver fuse element

Time-current characteristics acc. to VDE 0636-2 and IEC/EN 60269-2

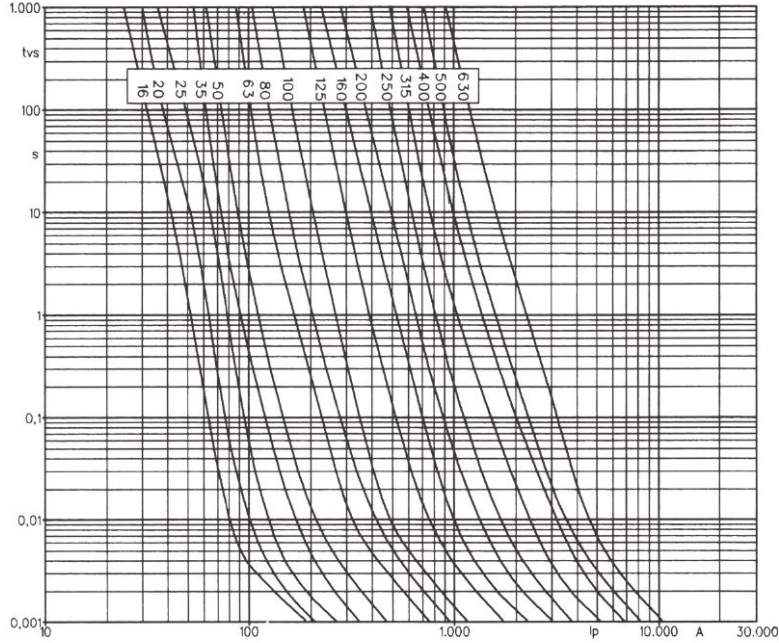

Force-distance diagram of the striker

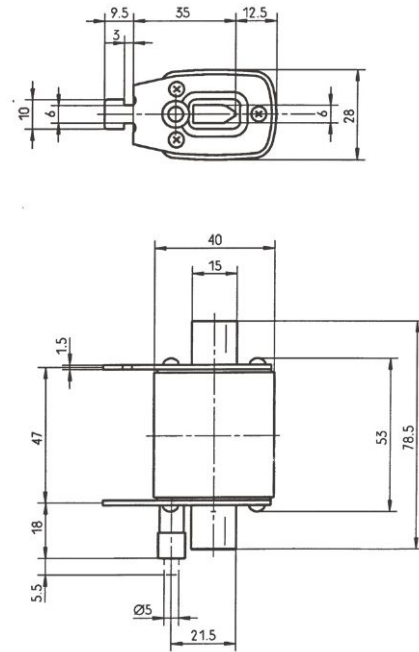
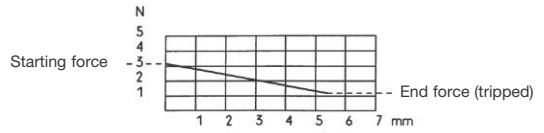

Cut-out current characteristics acc. to VDE 0636-2 and IEC/EN 60269-2

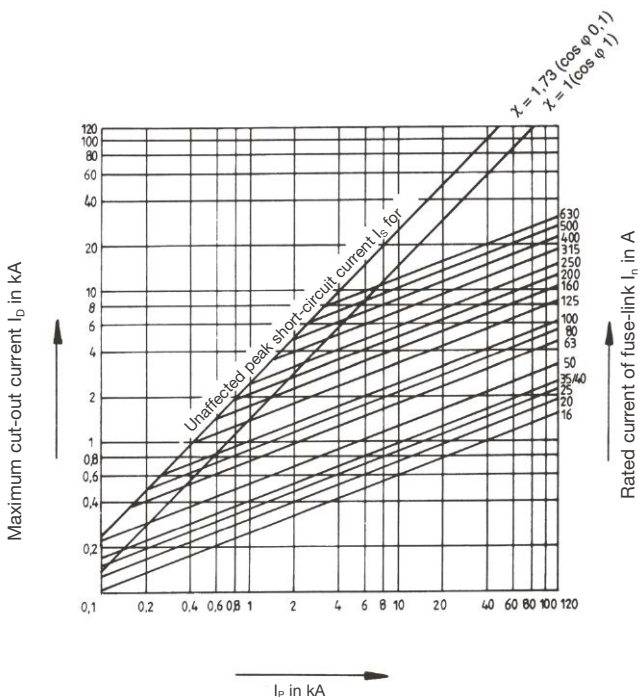

Pre-arcing and operating integrals acc. to VDE 0636-2 and IEC/EN 60269-2

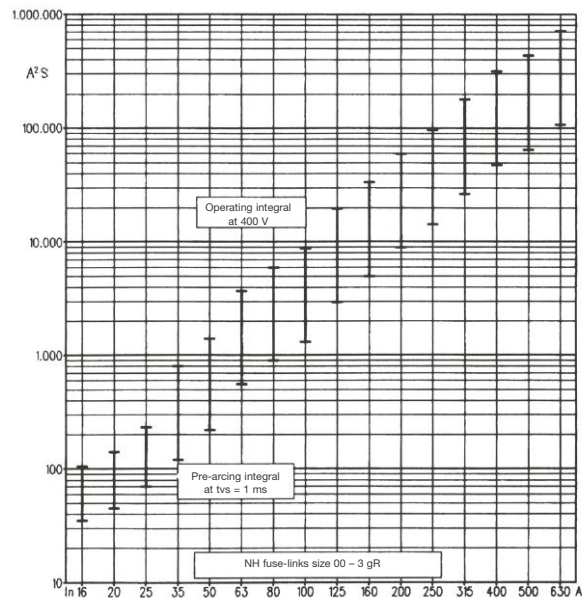

Ip acc. to prospective short-circuit current Ik at point of fault (DIN / VDE 0102 part 2)



## NH maintenance fuse-link

### Application:

NH maintenance fuse-links are used to temporarily replace line-protection fuse-links (gG) in power grids during maintenance work. The feature ultra-quick time-current characteristics. Accordingly, maximum cut-out current and maximum cut-out energy are limited even more strictly than in NH fuse-links of utilization category gG. This means less risk by potential current arcing to the maintenance personnel.

NH maintenance fuse-links are not optimally suited for normal operation as they trip more quickly in the case of temporary overload. Also, their power dissipation is much higher than that of fuse-links of category gG. For normal operation we recommend our ageing-resistant NH fuse-links of utilization category gG.

- Less cut-out energy and lower cut-out currents thanks to ultra-quick time-current characteristics means more safety for the maintenance personnel
- Insulated metal gripping lugs protect against accidental contact with live parts
- Ageing-resistant pure silver fuse element
- Locked screws that do not come lose
- Reliable function even after years inside a service vehicle
- Clear identification in red color as "maintenance fuse-link"

Size	Amps	Designation	Order no.
2	80	NH-Arbeitssicherung 80A gR Li	<b>35209-0010</b>
2	100	NH-Arbeitssicherung 100A gR Li	<b>35209-0020</b>
2	125	NH-Arbeitssicherung 125A gR Li	<b>35209-0030</b>
2	160	NH-Arbeitssicherung 160A gR Li	<b>35209-0040</b>
2	200	NH-Arbeitssicherung 200A gR Li	<b>35209-0050</b>
2	224	NH-Arbeitssicherung 224A gR Li	<b>35209-0060</b>
2	250	NH-Arbeitssicherung 250A gR Li	<b>35209-0070</b>
2	300	NH-Arbeitssicherung 300A gR Li	<b>35209-0080</b>
2	315	NH-Arbeitssicherung 315A gR Li	<b>35209-0090</b>

# NH maintenance fuse-link

Maintenance fuse-link and gG fuse-link compared

